

SKÄRNING Ø

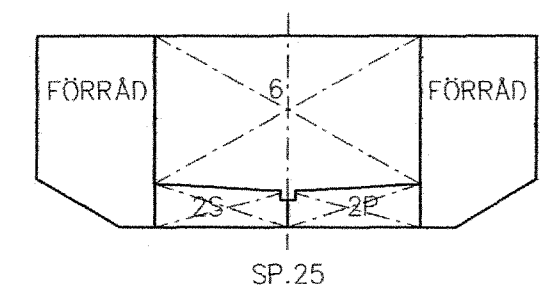
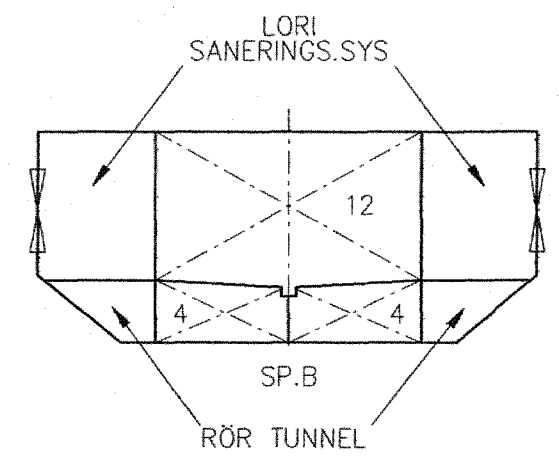
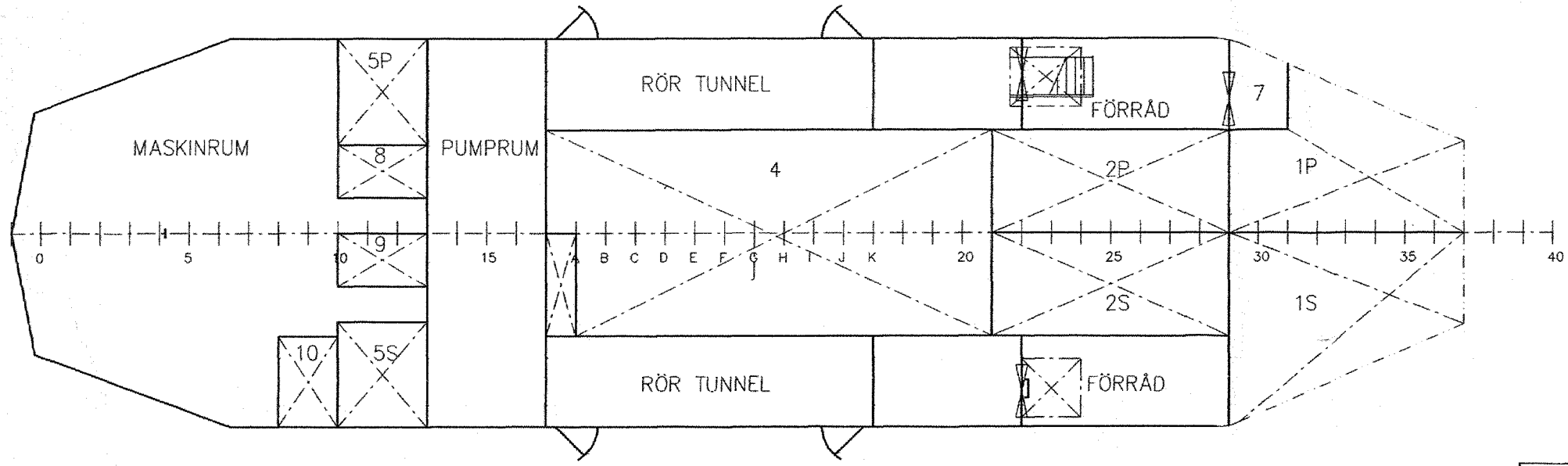
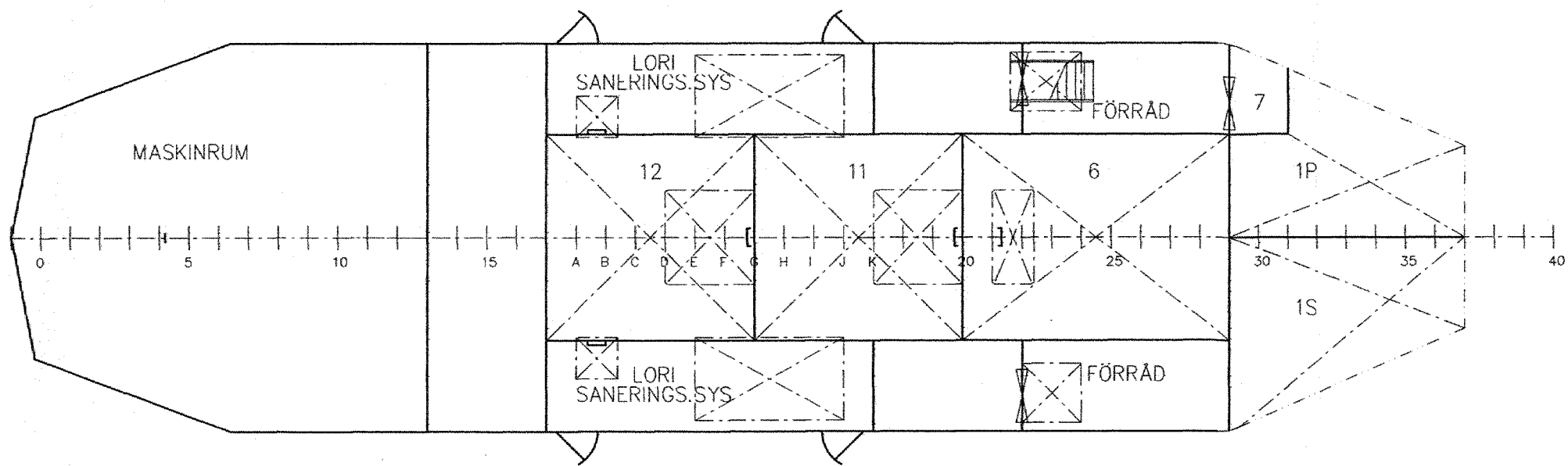

TANK	BENÄMNING	VOLYM
1 S	BARLAST	10,0 m ³
1 P	BARLAST	8,0 m ³
2 S	BARLAST	5,0 m ³
2 P	BARLAST	5,0 m ³
3	BOTTENBRUNN	
4	FÄRSKVATTEN	19,7 m ³
5 S	DIESEL	2,5 m ³
5 P	DIESEL	2,5 m ³
6	UPPSAMLINGSTANK	28,0 m ³
7	KETTING BOX	
8	SEPTIKTANK	1,50 m ³
9	FÄRSKVATTEN	1,50 m ³
10	SPILLOLJA	0,80 m ³
11	UPPSAMLINGSTANK	24,30 m ³
12	UPPSAMLINGSTANK	24,30 m ³

HUVUDDIMENSIONER:

STÖRSTA LÄNGD	24,50 m
BREDD MALLAD	6,60 m
SIDHÖJD MALLAD	2,75 m
MELELDJUPGÅNG	2,10 m
MASKINSTYRKA	268 kW

Ändring	Index	Datum	Ändr.	Gransk.
SKÄRGÅRDHAVETS SJÖFARTSDISTIKT FIN-22100 MARIEHAMN		m/s OILI 3 TANKPLAN		
RIT TJÄNST AB		Skala 1:100	Konstr. Ritad 2000.03.06. MK	Ritn. nr. RM 32616
MÅSVÄGEN 2 FIN-22100 MARIEHAMN TEL.018-15325, FAX.018-15324 e-mail: rittjanst@alond.net		Gransk.	Ersatt av.	Filnamn.